

LABELLE WOODWORKING COMPANY

KIT No. HO-9 CLOSED VESTIBULE SLEEPING CAR

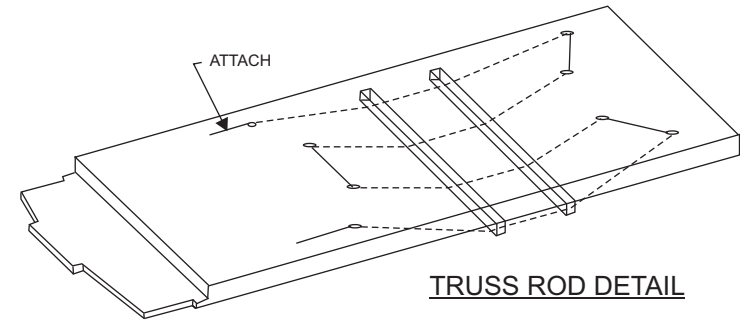

LaBelle Woodworking Company
 5101 Ridge Road
 Cheyenne, Wyoming 82009
 Phone :307-433-9909 Fax: 307-433-9949
 Toll Free: 866-246-9967 (Voice Only)
 e-mail: info@labellemodels.com

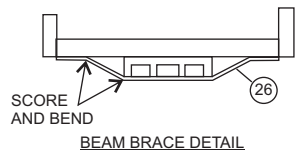
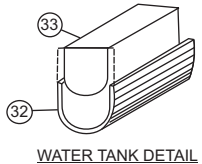
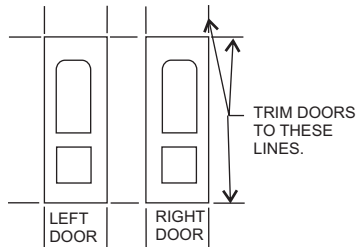
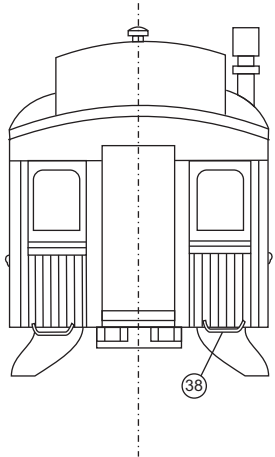
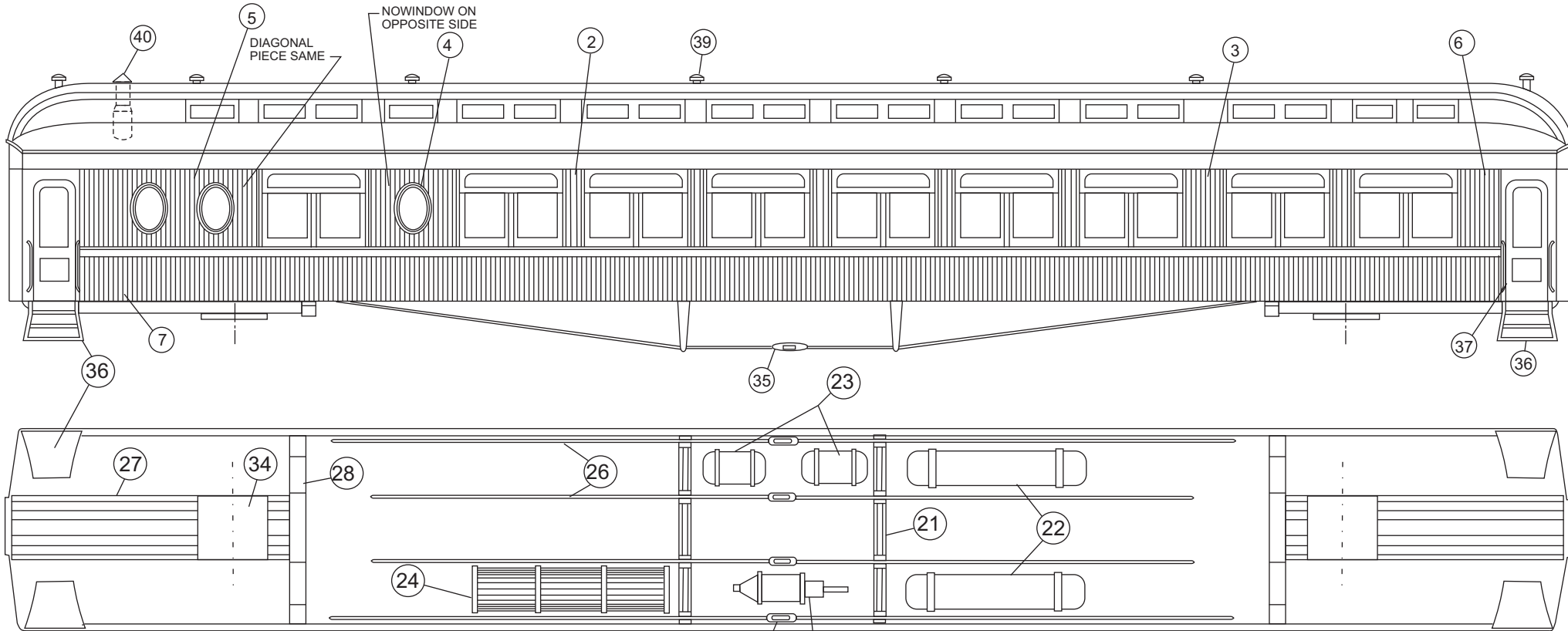
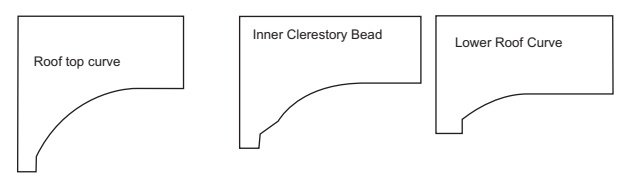
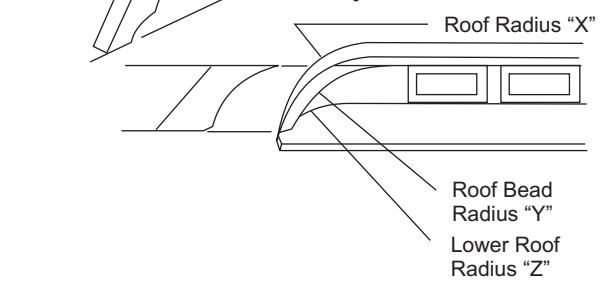
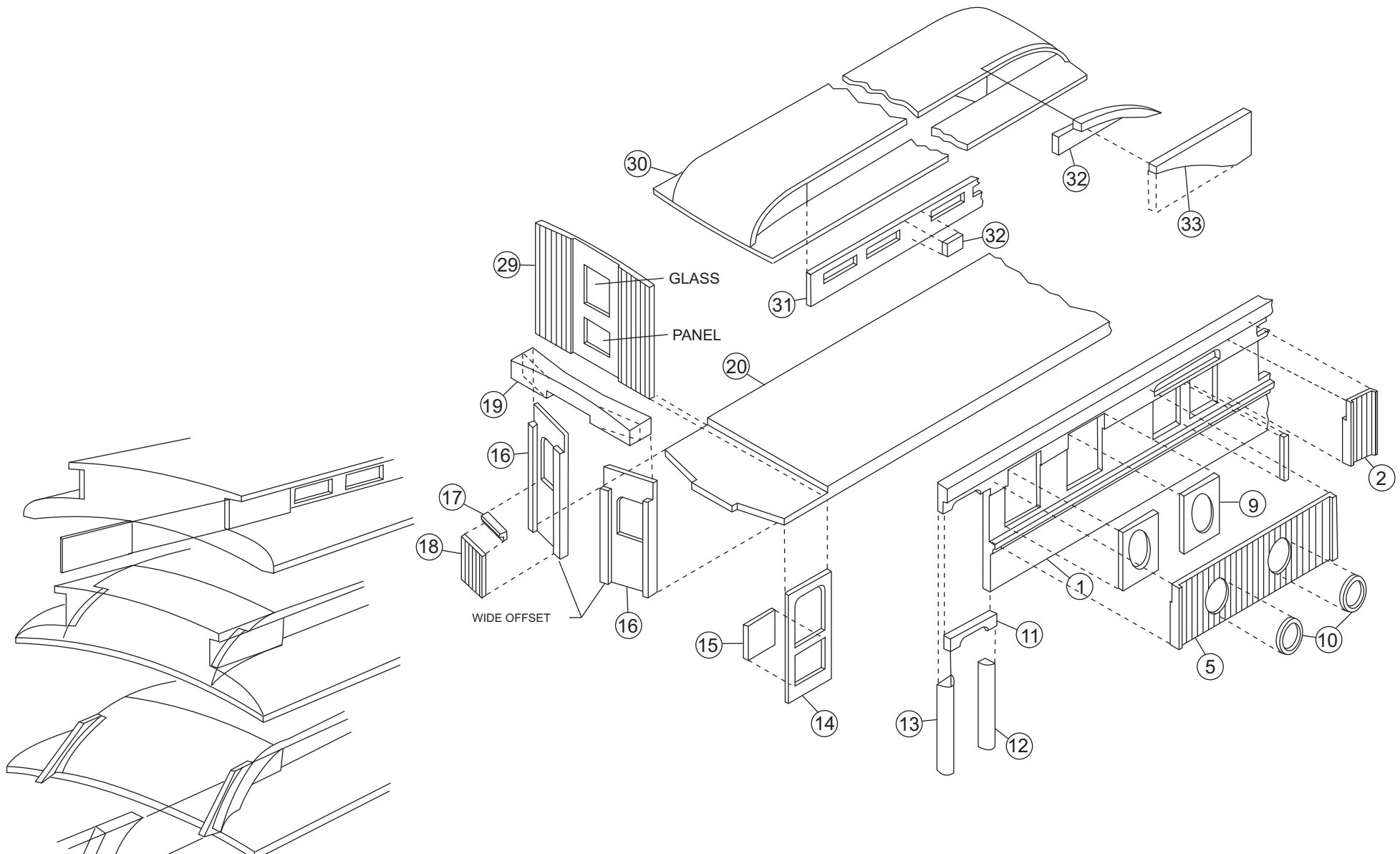

CLOSED VESTIBULE SLEEPER LABELLE WOODWORKING COMPANY KIT HO-09

This is a basic kit of an early 1900 SLEEPING CAR. It is not a “QUICKIE KIT” and therefore it is suggested that the ISOMETRIC and PLAN DRAWINGS be studied thoroughly, also that the parts be noted as to where they are intended to be used. It is suggested that assembly be followed by the NUMBERS in the Instructions which correspond with the NUMBERS on the ISOMETRIC and PLAN DRAWING.

CAUTION: Package marked “FRAGILE” should be handled “WITH GREAT CARE”. CAUTION!

These are the Sub-sides (1).

NOTE: All window posts are in “FRAGILE” pack.

Separate and trim edges of all Window Posts Flush with raised shouldlers.

Cement in their respective places Window Posts (2), (3), (4), and (5). Cut Window Posts (6) to approximate width from remaining piece and cement to their respective ends. Cement Siding (7) below belt rail. Sand Posts and Siding FLUSH with ends of sub-sides, and FLUSH at bottom. Separate Mullion Posts (8) from thin scribe piece 7/8 inch by 1 inch, cut to length and cement in place. Cut and fit Oval Window Inserts (9) strip to fit in square openings on back of sub-sides. **IMPORTANT:** Make sure Oval Openings align with Oval openings in Window Posts. **DO NOT** cement in place at this time. Cement in place Oval Window Castings (10).

Cut Doors (14) to size by placing doors over TEMPLATES, making sure that two (2) RIGHTS and two (2) LEFTS are made and used at their respective ends. Cut Door Panels (15) from 1/32 inch by 1/4 inch by 3 1/2 inch long stripwood and cement to back of doors. Cement doors to back of sub-sides at TOP ONLY, keeping Flush with bottom of sub-sides. Now contour door headers (11) (FRONT EDGE of notch ONLY) to MATCH Door Posts (12) (1/32 inch by 1/16 inch Quarter Round) and Door Posts (13) (1/16 inch by 1/16 inch Half Round). Cut to fit and cement in place.

Make up Vestibule End Pieces (16) by cutting to length and cementing in place Belt Rail (17) making sure CORRECT margin is maintained below windows as per END ELEVATION. Cut to length and cement in place Thin Siding (18). Now cement a completed Right (16) and Left (16) to End Letterboard (19) making sure WIDE OFFSETS are to center as per ISOMETRIC DRAWING.

Layout bottom of Floor (20) for position of Queenposts (21) Pintsch Gas Tanks (22) Air Tanks (23) Water Tank (24) Brake Cylinder (25) Truss Rods (26) Beams (27) and Beam Braces (28). Cut Door Panels and cement to back of Bulkhead walls (29). Cement Bulkhead Walls against rabbet in floor making SURE they are square. Cement completed Sides to Floor keeping Flush at bottom. Assemble Roof (30) by cementing Clerestory Window Inserts (31) inside of roof, as per PLAN DRAWING. **NOTE:** BOTH INSERTS Window Openings should ALIGN. Cut to length and cement in place Roof Window Casings (32) from 1/32 inch by 3/16 inch stripwood as per SIDE ELEVATION and ISOMETRIC DRAWINGS. Now Roof ends maybe rounded to CONTOUR SHOWN on PLAN DRAWING. Make TEMPLATE from card stock and use to check contour for correct shape. CARE should be taken when sanding roof ends to size so as not to sand too much off. Make up Overhang Pieces (33) for ends of roof from 1/16 inch by 1/2 inch stripwood and cement in place. Apply cement to end of floor and bottom of End Assembly.

TEMPORARILY place Roof on Car Body, holding Vestibule End Assembly up under Roof Contour and against end of floor until cement has set. Remove Roof and apply small fillet of cement inside where Vestibule End Assembly meets Vestibule Doors. After End Assembly has set, apply Door Posts (12) (1/32 inch by 1/16 inch Quarter Round) and (13) (1/16 inch by 1/16 inch Half Round) on Vestibule Doors as shown and sand Flush with bottom of floor. Make up Water Tank (24) as per DETAIL by soaking 7/8 inch by 1-7/16 inch scribed Tank Wrapper in hot water, placing it around Water Tank Form and holding in place with rubber bands until dry.

Cement Water Tank Wrapper to Water Tank Form. Sand Top and Ends Flush and cement in place.

Make up and cement in place Gas Tanks (22) and two (2) Air Tanks (23) as per DETAIL, Queenposts (21) Brake Cylinder (25) Truss Rods (26) Beams (27) Beam Braces (28) as per DETAIL and Bolster (34). NOTE: Position of Bolsters (TRUCK CENTERS) will be determined by Type and Make of Trucks used, also radii of curves car is to be operated over.

Install Turnbuckles (35) and Steps (36). Make up Handrails (37) and install. Add Grab Irons (38) Roof Vents (39) (brass escutcheon pins) and Chimney (40).

Car is ready for painting. After painting install Green Acetate for Clerestory Windows in Roof, Oval and Upper Windows in Sides. Clear Acetate for Lower Windows and Doors. Cement in place Oval Window INSERTS (9). Attach Diaphragms (Not Supplied). What the Heck is a Window Post?

All of our passenger car and trolley kits use them, but the instructions are a little vague about what they look like and how to use them. This should explain them a little better.

In general, they are the scribed pieces which fit between the windows on the car side. They also have a small raised rib, called a “raised shoulder” on each end of the scribed section. This raised shoulder forms one edge of the window frame. Actual size and shape varies according to the kit, but the use is always the same.

When assembled, each raised rib will go next to a window opening, and the scribe will be trimmed to extend half way to the next window. The next one is the same, with the scribing trimmed to match the joint form the first. This will give a rib for the side of each window frame with scribing in between. You will have the trimmed pieces August 7, 2001 of scribing left over which may be discarded.



LaBelle Woodworking Company
5101 Ridge Road
Cheyenne, Wyoming 82009
Phone :307-433-9909 Fax: 307-433-9949
Toll Free: 866-246-9967 (Voice Only)
e-mail: info@labellemodels.com